

Condensate Pump Kit Installation Manual

484007-5000

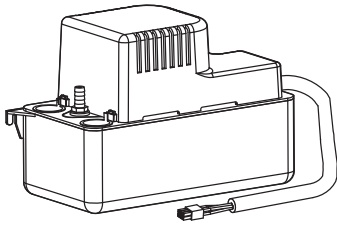

Condensate Pump (1)

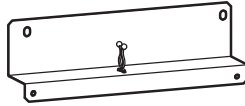

Adapter Plate (1)

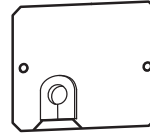

Connector Cover Plate
with Grommet (1)



Hose Clamp (1)

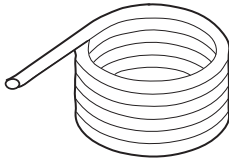

Outlet Hose (1)
20 ft (6.0 m)
Φ3/8 in (9.5 mm)

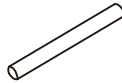

Drain Inlet Hose (1)
1 ft (0.3 m)
Φ1/2 in (12 mm)



Screw w/Washer (2)
M4 × L10



Screw w/Washer (2)
M6 × L12

Model Name	Climate Pro X14/20, K12/18, D12/18	Climate Pro X26, K24
Part No. (voltage)	484789-0210 (115V)	484789-0220 (208/230V)

If the parts appear to be damaged or missing, contact your MovinCool dealer.

WARNING

Disconnect power before installation. Beware that some residual voltage may remain in the unit after the power is disconnected. There is a risk of electric shock.

PUMP INSTALLATION

1. Open the drain tank cover and remove the tank from the unit.
2. Punch out the knock-off hole in the side panel using a tool such as a screwdriver. This hole is used to pass through the outlet hose.

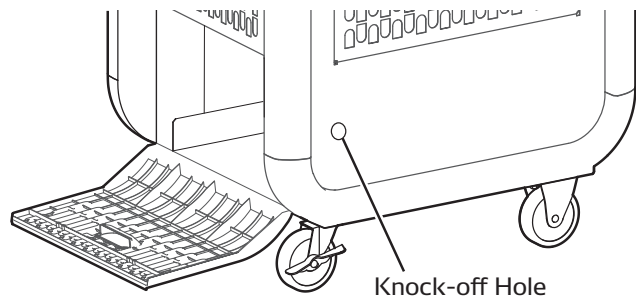

- Take out the two (2) screws and remove the connector cover plate.

Note:

- The screws will be required for installing the supplied connector cover plate in procedure 9.

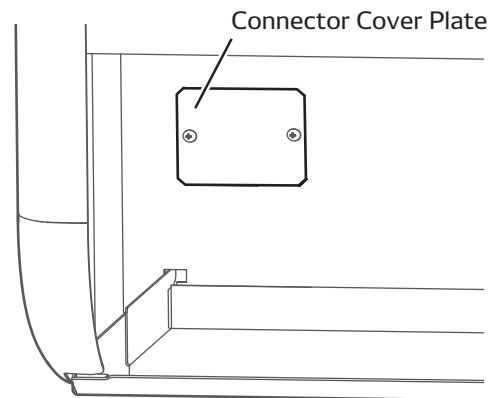

- Push down on the top of the jumper plug as shown, and pull it out from the mating connector.

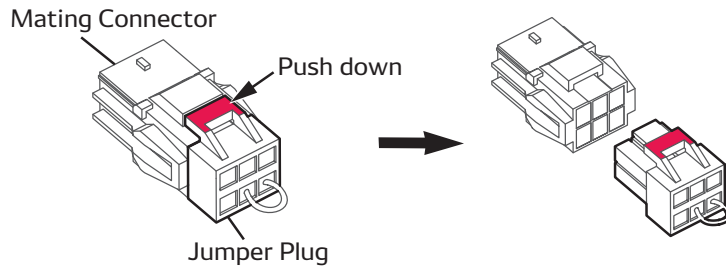

Note:

- Retain the jumper plug and the connector cover plate in a safe place to reuse if condensate pump is removed.

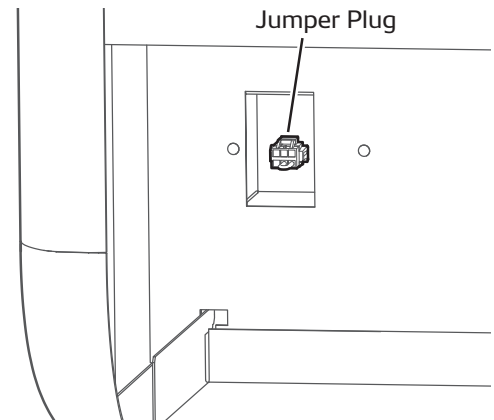

- Remove the tab and cap as shown from the condensate pump.

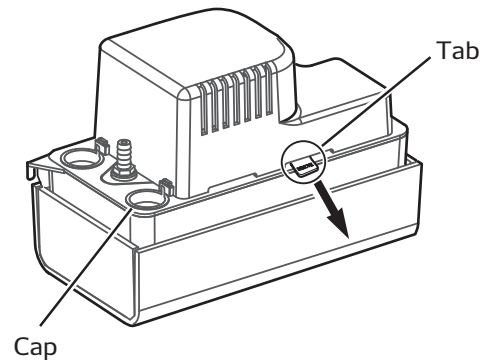

- Secure the pump to the adapter plate.

Detailed procedure is as follows:

- Insert the two (2) screws (M4 x L10) into the bottom holes of the adapter plate.
- Slide the mounting slots of the pump over the screws.
- Secure the screws.

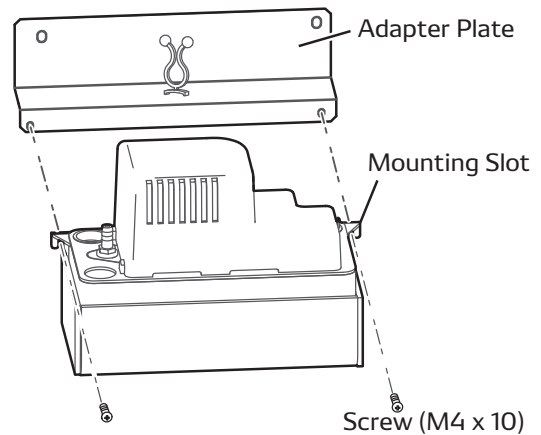

- d) Pass the connector cable through the twist cable tie and secure the connector cable by twisting the tie.

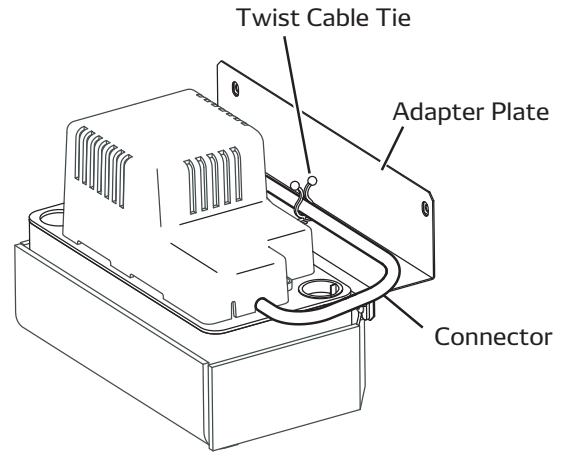

7. Mount the pump to the inside drain tank frame with the two (2) screws (M6 x L12).

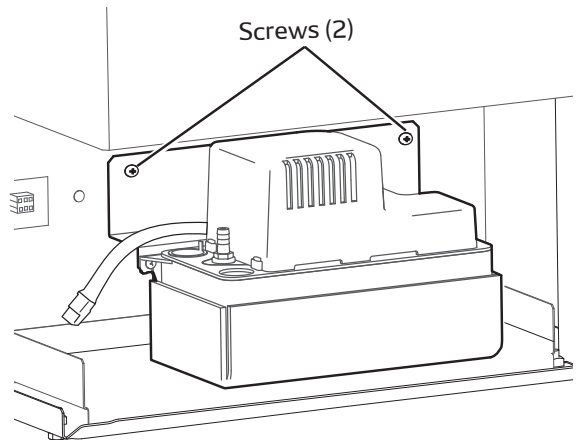

8. Connect the pump connector to the mating connector.

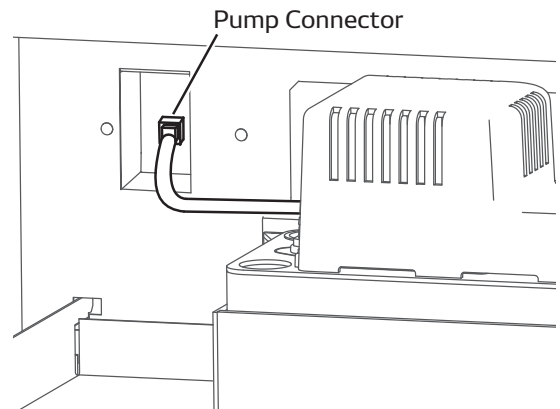

9. Install the supplied connector cover plate with the two (2) screws, which were removed in procedure 6. The wire of the connector can be passed through the grommet.

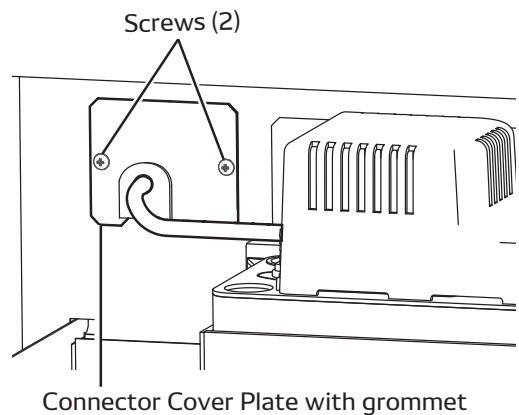

HOSE INSTALLATION

1. Pass the hose clamp through the inlet hose. Connect one end of the inlet hose to the drain stem of the unit and secure with the hose clamp by removing the tab as shown.
2. Insert the other end of the inlet hose into the inlet hole.
3. Unwind the outlet hose and connect to the drain outlet spout of the pump.
4. Pass the other end of the outlet hose through the knock-out hole in the side panel.

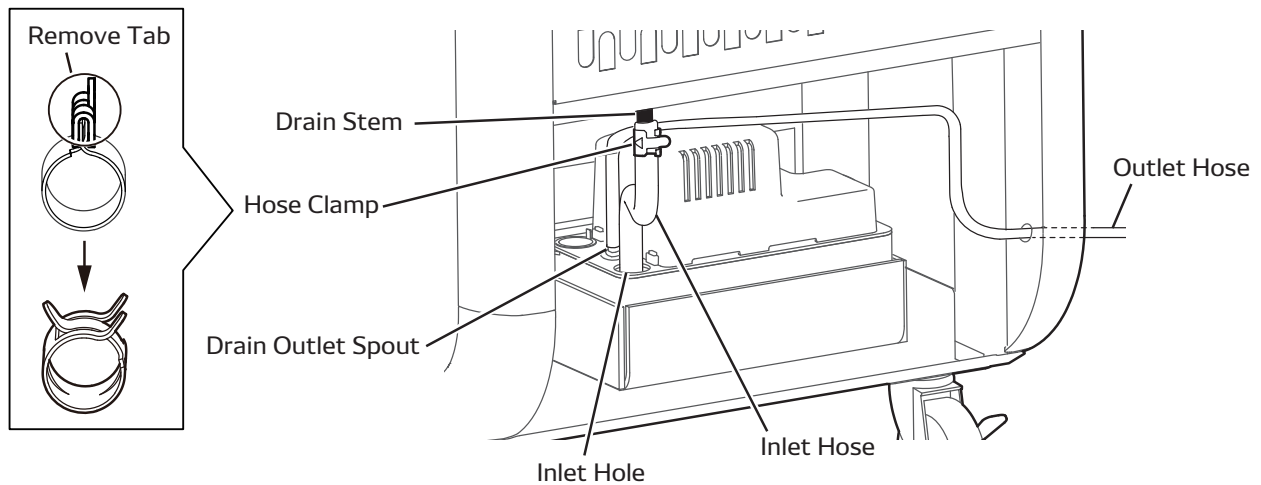

⚠ CAUTION

Ensure smooth drainage through the hose. If the hose is kinked or clogged, it may cause malfunction and property damage due to water leaks.

When hanging the hose from the ceiling, the maximum height for lifting the hose vertically depends on the voltage that the unit uses. Check the maximum hose height in the table below. Run the drain hose on a downward slope at a minimum rate of 1/4 inch(6.25mm) per foot.

Voltage	Max. height for lifting
115 VAC	20 feet (6.0 m)
230 VAC	17 feet (5.2 m)
208 VAC	13 feet (4.0 m)

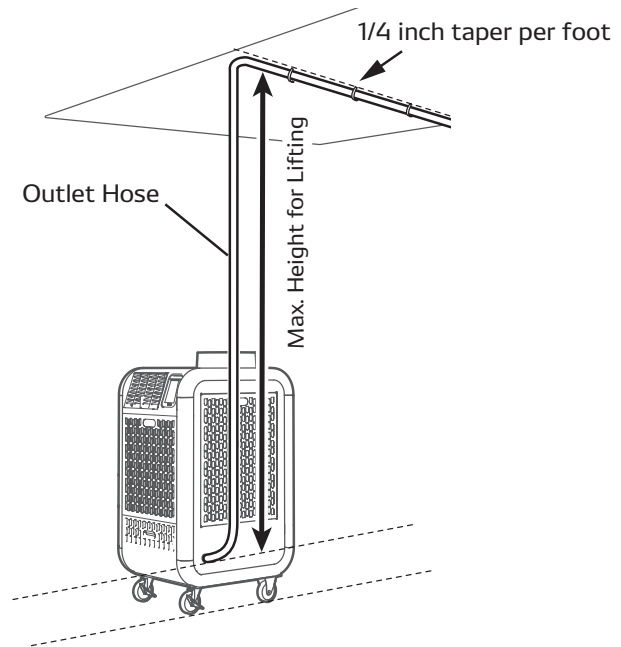

TESTING

1. Turn the unit on.
2. Take out the end of the inlet hose from the inlet hole.
3. Pour water into the pump reservoir from the inlet hole.
4. Make sure that the pump starts running and water is drained through the outlet hose.
5. Reinsert the end of the inlet hose into the inlet hole.