

QDS081 25-40 HP Air and Nitrogen Booster

Trust Quincy's line of Oil-Free Air and Nitrogen boosters for your critical project needs. Designed to prevent contamination and losses of the gas stream, these units provide worry free operation and a 20+ year life expectancy.



QDS081 25-40 HP Air and Nitrogen Booster

The QDS081 Features:

- ✓ 100% oil-free gas stream
- ✓ ISO 8573-1 compliance eliminates risk to product and equipment
- ✓ Durable cast iron and steel construction
- ✓ 24 hour duty cycle
- ✓ Simple annual maintenance
- ✓ 24 hour live tech support
- ✓ Made in the USA

QDS081 25-40 HP CAPACITY

Suction Pressure (PSIG)	Discharge Pressure (PSIG)	Minimum Flow (SCFM)	25 HP Maximum Flow (SCFM)	30 HP Maximum Flow (SCFM)	40 HP Maximum Flow (SCFM)
70	300	57.7	99.8	N/A	N/A
70	400	55.7	83.5	96.3	N/A
70	450	54.7	78.0	88.3	94.7
70	500	53.8	72.5	87.0	93.2
70	600	52.2	66.2	78.2	90.2
80	300	65.3	105.5	113.2	N/A
80	400	63.2	90.2	109.5	N/A
80	450	62.3	83.8	100.7	107.8
80	500	61.3	78.0	92.0	106.2
80	550	60.5	74.5	86.2	104.7
90	400	71.0	98.2	114.5	122.7
90	450	70.0	88.7	105.0	121.0
90	500	69.0	84.8	98.2	119.5
90	550	68.0	78.5	94.2	117.7
100	400	78.5	105.7	126.8	136.0
100	450	77.5	95.5	116.3	134.2
100	500	76.5	88.5	106.0	132.5

Table based on 80F suction temperature at sea level. Cooling fan option may be required to reach maximum flow.

Contact Quincy Compressor for specific capacity at given conditions.

To ensure we are constantly improving, Quincy Compressor reserves the right to make changes without prior notification.

QDS081 25-40 HP Air and Nitrogen Booster

Dimensions

Length:	56"
Overall Width (*W1):	54"
Skid Width (W2):	30"
Height:	58"
Estimated Weight:	2,000 lbs
Estimated Shipping Weight:	2,450 lbs
Suction (FNPT):	2"
Discharge (FNPT):	3/4"
Instrument Ports (FNPT):	1/4"

Technical Specifications

Bore:	4.50" x 2.75"
Stroke:	4.00"
No. of Stages:	2
No. of Cylinders:	2
Cooling:	Air
Controls:	PLC Touch Screen Interface
Compressor Model:	2AN22E

Utility Requirements

Power (25 HP):	460/3/60 34.3 FLA
Power (30 HP):	460/3/60 41.3 FLA
Power (40 HP):	460/3/60 53.5 FLA

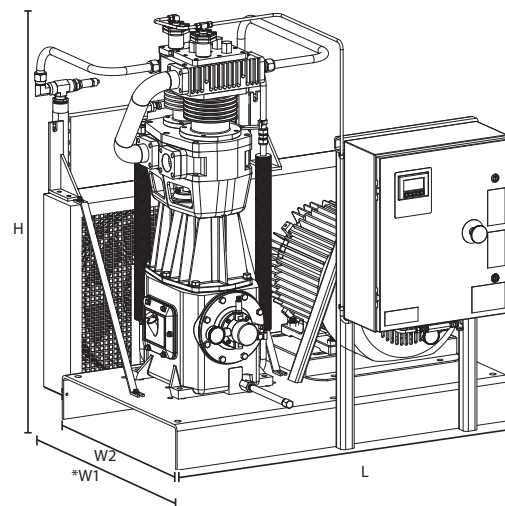

*Includes front control panel and rear belt guard assembly.

Options

- Auxiliary Cooling Fan
- Cold Weather Packaging
- Duplex Programming
- Multiple Voltages
- Modbus Gateway
- Moisture Separators
- DSi Install Kit Includes
 - Filters
 - Regulators
 - Tanks
 - Flex Hoses