

QDS015 Air and Nitrogen Booster

Trust Quincy's line of Oil-Free Air and Nitrogen boosters for your critical project needs. Designed to prevent contamination and losses of the gas stream, these units provide worry free operation and a 20+ year life expectancy.

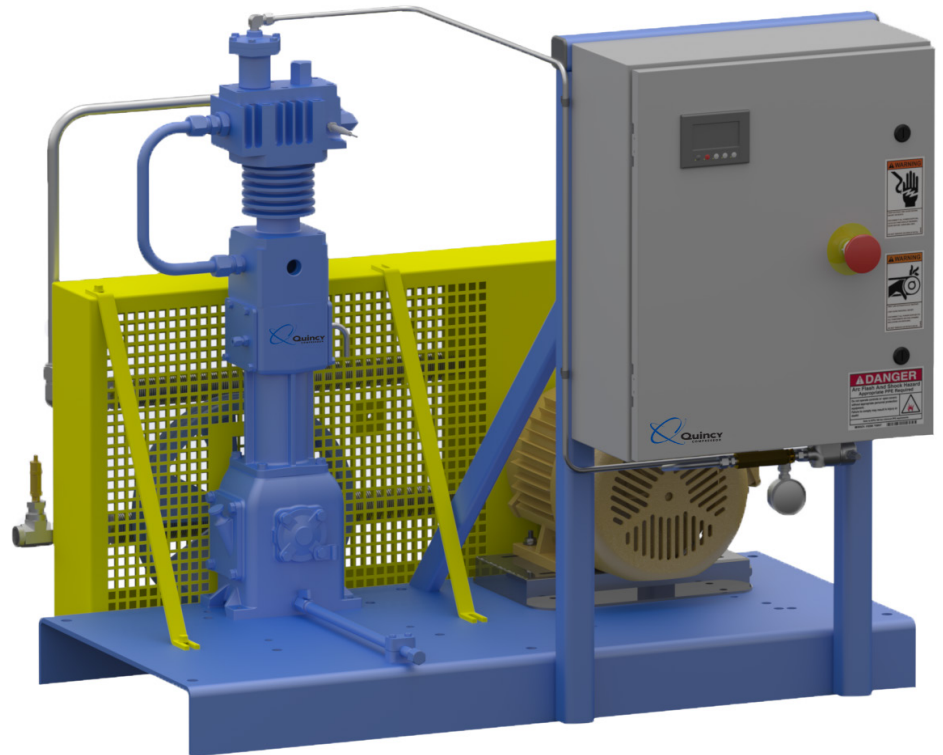

QDS015 Air and Nitrogen Booster

The QDS015 Features:

- ✓ 100% oil-free gas stream
- ✓ ISO 8573-1 compliance eliminates risk to product and equipment
- ✓ Durable cast iron and steel construction
- ✓ 24 hour duty cycle
- ✓ Simple annual maintenance
- ✓ 24 hour live tech support
- ✓ Made in the USA

QDS015 CAPACITY

Suction Pressure (PSIG)	Discharge Pressure (PSIG)	Minimum Flow (SCFM)	5 HP Maximum Flow (SCFM)
70	200	11.7	17.5
70	250	11.2	16.7
80	200	13.3	20.0
80	250	12.8	19.2
80	300	12.3	16.5
90	200	15.0	22.5
90	250	14.5	21.7
90	300	14.0	20.8
100	200	16.7	25.0
100	250	16.2	24.2
100	300	15.7	23.3

Table based on 80F suction temperature at sea level. Cooling fan option may be required to reach maximum flow.

Contact Quincy Compressor for specific capacity at given conditions.

To ensure we are constantly improving, Quincy Compressor reserves the right to make changes without prior notification.

QDS015 Air and Nitrogen Booster

Dimensions

Length:	50"
Overall Width (*W1):	46"
Skid Width (W2):	23"
Height:	46"
Estimated Weight:	700 lbs
Estimated Shipping Weight:	950 lbs
Suction (FNPT):	3/4"
Discharge (FNPT):	3/4"
Instrument Ports (FNPT):	1/4"

Technical Specifications

Bore:	2.25"
Stroke:	2.50"
No. of Stages:	1
No. of Cylinders:	1
Cooling:	Air
Controls:	PLC Touch Screen Interface
Compressor Model:	AN3.4A

Utility Requirements

Power (5 HP):	460/3/60 7.3 FLA
---------------	------------------

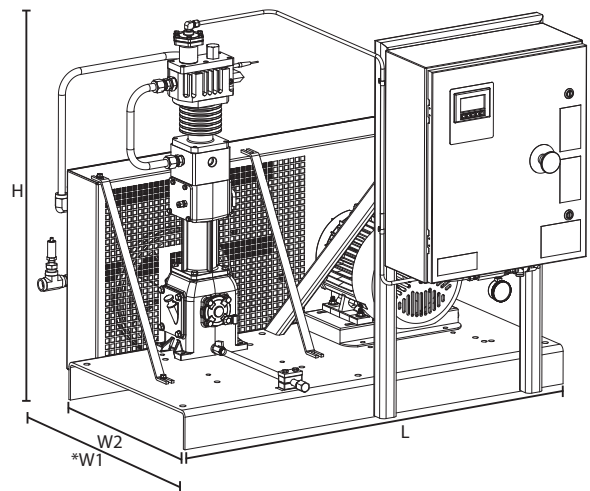

*Includes front control panel and rear belt guard assembly.

Options

- Auxiliary Cooling Fan
- Cold Weather Packaging
- Duplex Programming
- Multiple Voltages
- Modbus Gateway
- Moisture Separators
- DSi Install Kit Includes
 - Filters
 - Regulators
 - Tanks
 - Flex Hoses