

PRESSURE FLOW CONTROL



Most plants strive to operate their compressed air system at elevated pressures to protect against periods of peak air demand that cause plant pressure to fall. As a result, the header pressure fluctuates widely, causing problems with production equipment and processes. The Quincy PFC Pressure Flow Control is a highly engineered pressure/flow controller, designed to put an end to fluctuating header pressure.

The Quincy PFC uses a PID electronic control that intelligently adjusts the butterfly valve position to stabilize plant pressure. This means that the Quincy PFC steadies plant header pressure, reduces air usage and limits the number of compressors needed on-line - all of which results in increased production, higher quality products, improved process control and reduced operating costs.

Dual digital pressure display allows convenient adjustment of the plant pressure

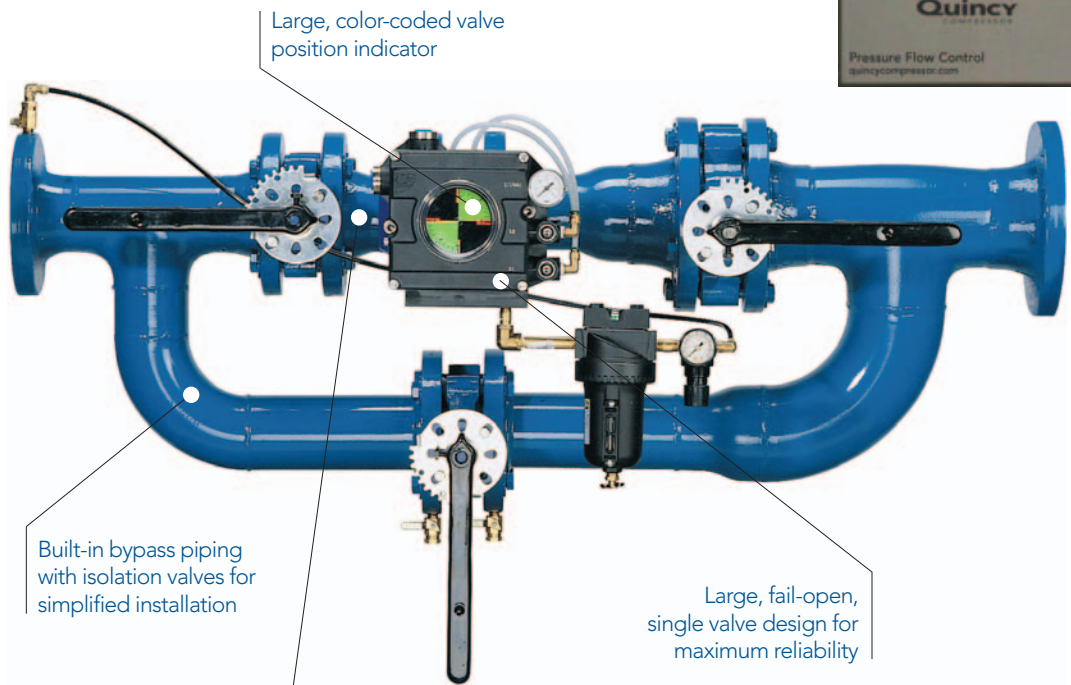

Large, color-coded valve position indicator

Built-in bypass piping with isolation valves for simplified installation

Large, fail-open, single valve design for maximum reliability

1 psi or less pressure drop at highest flow rating for maximum efficiency

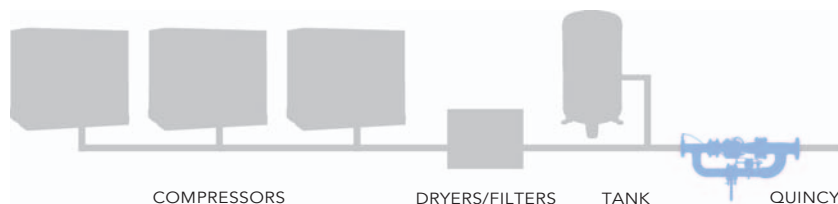

PRESSURE FLOW CONTROL

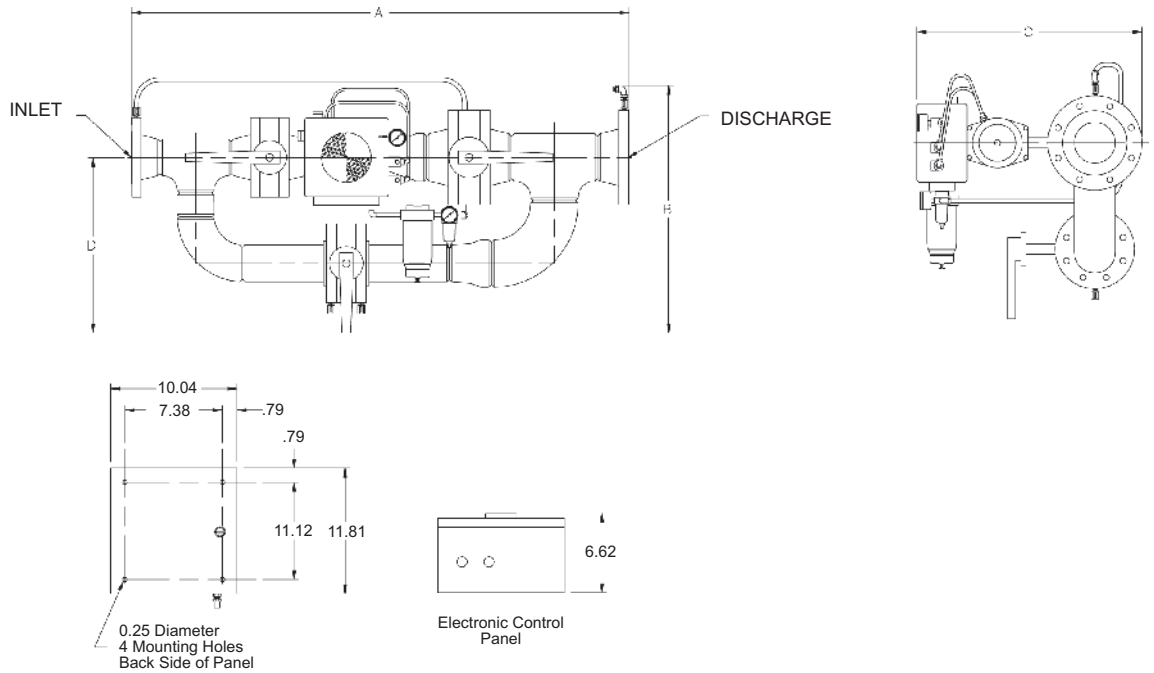

Model Number	Inlet	Discharge	Max scfm	Weight lbs.	Approximate Dimensions (inches)			
					A	B	C	D
PFC 3x2x3	3" ANSI	3" ANSI	800	210 lb	46.75"	24.00"	18.00"	18.50"
PFC 3x4	3" ANSI	4" ANSI	1800	306 lb	47.25"	31.36"	18.72"	20.74"
PFC 4x6	4" ANSI	6" ANSI	3000	459 lb	56.60"	35.86"	21.38"	25.24"
PFC 5x6	5" ANSI	6" ANSI	6000	647 lb	60.85"	35.86"	21.88"	25.25"
PFC 6x8	6" ANSI	8" ANSI	8000	692 lb	67.48"	41.37"	24.43"	29.62"

Notes:

- Flanges are class 150 with raised gasket face
- Maximum Inlet Pressure - 175 psig
- For information on pneumatic bypass, backpressure control, large capacity dual-valve and other custom valve configurations and options - please consult factory
- The maximum flow is based on a one psid control differ

QUINCY SYSTEMS CAPABILITIES

Engineered for your compressed air system, Quincy's complete line of analysis services and compressed air products will optimize your system. Whether you're installing a new compressed air system, or upgrading your exist-

ing system, every Quincy component has been designed for maximum productivity. Backed by renowned innovation and reliability - let Quincy Systems work for you.